



Date: 23/10/2019

EVENT REPORT

1	Name of the Event	"One Week Hands-on Training on AutoCAD "
2	Day & Date of the Event	15 th Oct. 2019 to 19 th Oct. 2019
3	Time of the Event	10:30 am to 04:30 pm
4	Venue of the Event	C 105 Cad lab I, Mechanical Engineering Department.
Sr. No	Objective	Expected Outcomes
1	To study sketching and taking field dimensions.	Students will learn about design and opportunities in the field of design engineering.
2	To study basic engineering drawing formats.	Students will become familiar with AutoCad two-dimensional and 3D drawings.
3	To provide In house training of various design tools and parameters.	Students will develop good communication skills and teamwork.

5 Description

(a)Introduction, Theme & Significance

a) Introduction

AutoCAD is a commercial computer-aided design (CAD) and drafting software application. Developed and marketed by Autodesk,. AutoCAD was first released in December 1982 as a desktop app running on microcomputers with internal graphics controllers. Before AutoCAD was introduced, most commercial CAD programs ran on mainframe computers or minicomputers, with each CAD operator (user) working at a separate graphics terminal. AutoCAD has several applications but mainly for Mechanical Engineering Applications AutoCAD Mechanical is mostly used in industry.



b) Theme

In mechanical engineering/industry we used to design the structure of components or machine members with the help of AutoCAD.

As it is a basic software, we can make 2-D designs more effectively than 3-D. (We can also design in 3-D, but remaining advanced software's are flexible comparatively with AutoCAD)

In some designing and manufacturing industries, the design made in AutoCAD software was directly applied by the machines (CNC) on the product, called as CAM.

c) Significance

In this fundamental course, students will be introduced to the basics of engineering drawing. Terms and definitions used in industries, such as manufacturing and construction, may also be covered. Specific skills introduced in this course may include sketching, geometric construction, auxiliary drawing, computing dimensions and lettering. Students will be also introduced to computer-aided drawing (CAD) software or techniques.

(b) Conduction, Guest details, Activity

a) Conduction

Mechanical department conducted "**One Week Hands-on Training on AutoCAD**" for Second and Third Year students of Mechanical Engineering Department.

b) Guest details

Mr.Sachin Pardeshi
CADCENTRE Wagholi
Pune.

d) Activity

One Week Hands-on Training on AutoCAD includes basic knowledge of AUTOCAD software, its use, functions, applications in various industries like Automobile industry Ship building, Industrial Equipment, Aerospace etc.



c) Students & Faculty response & participation

a) Students Response:

More than 50 students of Second & Third Year Mechanical Engineering were attending these training Sessions conducted in One weeks and 6 hours per day. The student's response was excellent and they built their confidence about various software handling and improve the confidence.

Event Photos:



Training session conducted by trainer.

Sign:
Name: Prof. N. Kadlak
Co-ordinator

Sign:
Name: Dr. Sarje S.H.
HOD

Sign:
Name: Dr. D.D. Shah
Principial



JSPM's
Imperial College of Engineering and Research, Wagholi, Pune.
(Approved by AICTE, Delhi & Govt. of Maharashtra, affiliated to Savitribai Phule Pune University)
Gat.No.720,Pune-Nagar Road,Wagholi,Pune,412207



Accredited with NAAC "A" Grade

Workshop Syllabus:-

1. Interface, Drawing Aids & Basic Objects
2. Complex Objects & Object editing
3. Blocks & Annotations
4. Plotting & Introduction to 3D



Accredited with NAAC "A" Grade

Assessment-Making 3D Object by using various commands

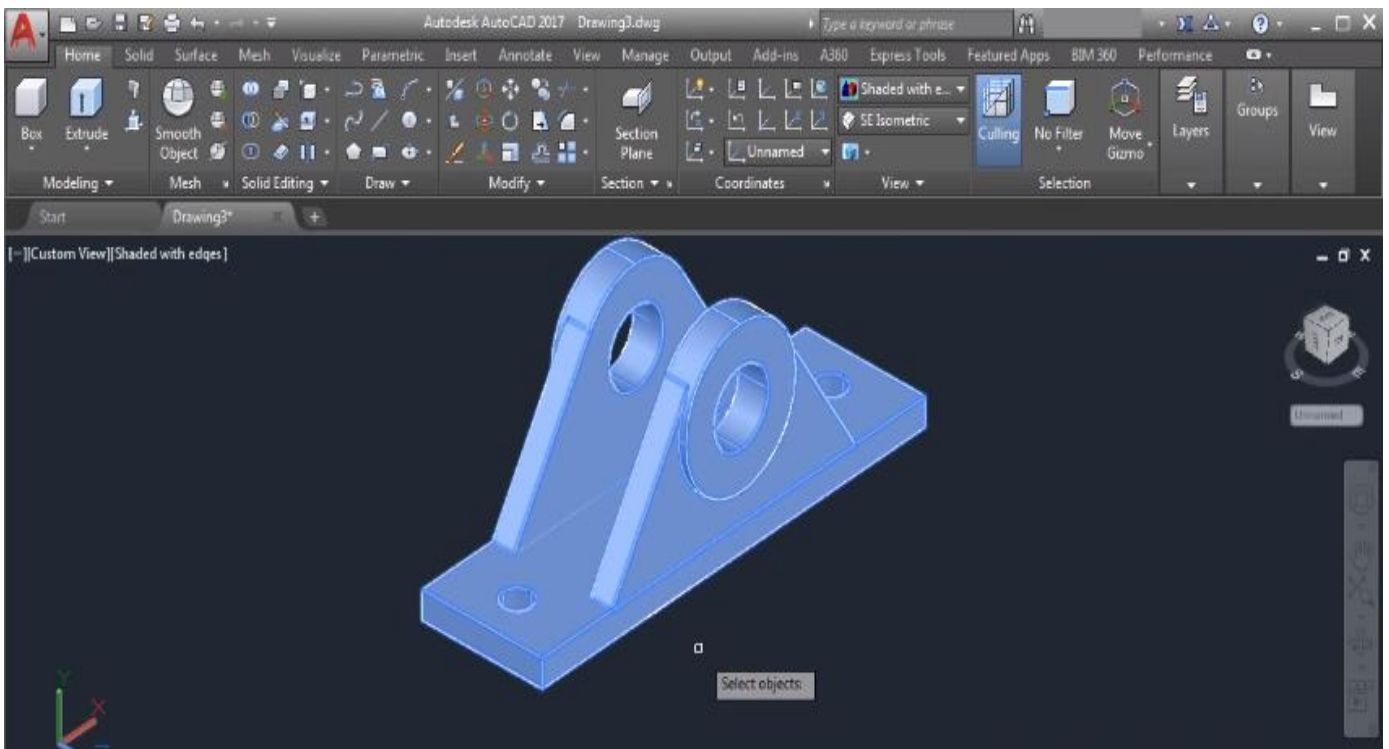
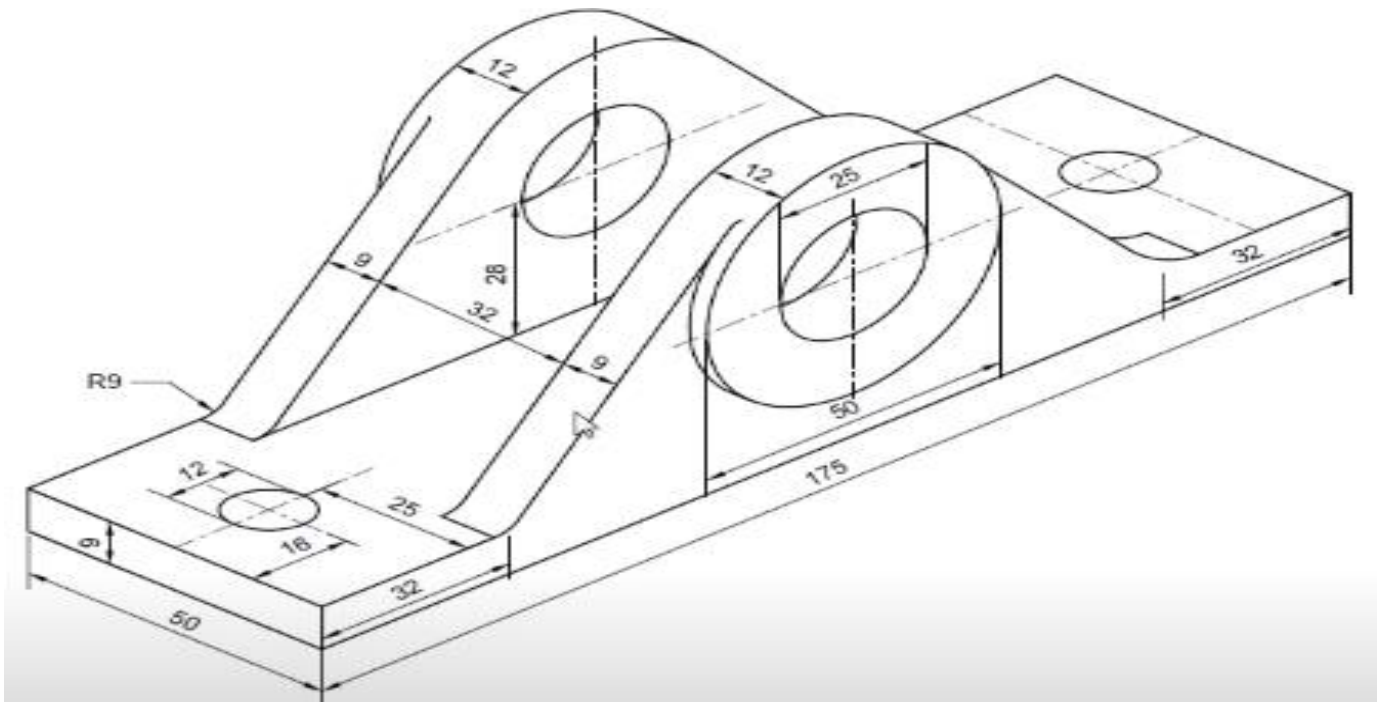

Autocad workshop - List of Enrolled participants .

Sr.No	Name of Participant	Sign
1	BHUJBAL SHUBHAM SUDAM	Bhubal
2	BANKAR TEJAS BABASAHEB	Bankar
3	balkrushan sirsakar	Balkrushan
4	PAWANKUMAR PAWAR	Pawar
5	SNEHAL SAKALKAR	Snehal
6	NADAR SHISUNDAR	Nadar
7	GAJARE ASHISH SANJAY	Gajare
8	BALI AKASH RAJKUMAR	Bali
9	SHANTANU AMBEKAR	Shantanu
10	BIRADAR ABHISHEK SURYAKANT	Biradar
11	BORAWANE SUHAS BALASO	Borawane
12	AKSHAY KOTKAR	Akshay
13	CHENDKE MADHUSUDHAN TANAJI	Chendke
14	AKSHAY KUMBHAR	Akshay
15	DIGVIJAY PAWAR	Digvijay
16	MEDIBOYNA RAVIKUMAR	Mediboyna
17	SANDIP HIPPARGEKAR	Sandip
18	ANUJ AMRUTKAR	Anuj
19	CHIKANE VIJAY BALKRUSHNA	Chikane
20	GHUGE SATISHKUMAR BALASAHEB	Ghughe
21	HARSHAL SURESH BARANGE	Harshal
22	KAUSTUBH KANGAONKAR	Kaustubh
23	LAXMIKANT KHEDKAR	Laxmikant
24	AKSHAY KHEDKAR	Akshay
25	DARESH PAWAR	Daresh
26	SHUBHAM KUMBHAR	Shubham
27	DARANDALE RUSHIKESH SACHIN	Darandale
28	KHOCHARE DEEAPK KANTILAL	Khochare
29	NAGRAJ KALYANKAR	Nagraj
30	SHITAL BHASAR	Shital
31	BAHIRE ISHWAR	Bahire
32	ASHRUBA DEVKAR	Ashruba
33	ANAND GAYKAR	Anand
34	DHIRAJ KINHOLKAR	Dhiraj
35	BHITE MAYUR ASHOK	Bhite
36	PAVAN PAWAR	Pavan
37	AKSHAY KUMBHAR	Akshay
38	BOROLE JAYESH RAJENDRA	Borole
39	JADHAV KUNAL BALU	Jadhav
40	MAYUR PAWAR	Mayur
41	BHUJBAL ABHISHEK EKNATH	Bhubal
42	RODGE RAJKUMAR	Rodge
43	DHOBAL BHUSHAN ABASAHEB	Dhobale
44	DHAVAL ANIKET SHIVAJI	Dhaval
45	CHAKKAR DEEP VINAYAK	Chakar
46	ABHISHEK THAKUR	Abhishek
47	HARSHAL PAWAR	Harshal
48	KOTKAR JAYESH ARUN	Kotkar

Attendance For Autocad workshop

15th Oct. 2019.

Sr.No	Name of Participant	Sign
1	BHUIBAL SHUBHAM SUDAM	Shubham
2	BANKAR TEJAS BABASAHEB	Tejas
3	balkrushan sirsakar	sirsakar
4	PAWANKUMAR PAWAR	Pawar
5	SNEHAL SAKALKAR	Snehal
6	NADAR SHISUNDAR	Nadar
7	GAJARE ASHISH SANJAY	Gajare
8	BALI AKASH RAJKUMAR	Bali
9	SHANTANU AMBEKAR	Shantanu
10	BIRADAR ABHISHEK SURYAKANT	Biradar
11	BORAWANE SUHAS BALASO	Borawane
12	AKSHAY KOTKAR	Akshay
13	CHENDKE MADHUSUDHAN TANAJI	Chendke
14	AKSHAY KUMBHAR	Akshay
15	DIGVIJAY PAWAR	Digvijay
16	MEDIBOYNA RAVIKUMAR	Mediboyna
17	SANDIP HIPPARGEKAR	Sandip
18	ANUJ AMRUTKAR	Anuj
19	CHIKANE VIJAY BALKRUSHNA	Chikane
20	GHUGE SATISHKUMAR BALASAHEB	Ghughe
21	HARSHAL SURESH BARANGE	Harshal
22	KAUSTUBH KANGAONKAR	Kaustubh
23	LAXMIKANT KHEDKAR	Laxmikant
24	AKSHAY KHEDKAR	Akshay
25	DARESH PAWAR	Daresh
26	SHUBHAM KUMBHAR	Shubham
27	DARANDALE RUSHIKESH SACHIN	Darandale
28	KHOCHARE DEEAPK KANTILAL	Khochare
29	NAGRAJ KALYANKAR	Nagraj
30	SHITAL BHASAR	Shital
31	BAHIRE ISHWAR	Bahire
32	ASHRUBA DEVKAR	Ashruba
33	ANAND GAYKAR	Anand
34	DHIRAJ KINHOLKAR	Dhiraj
35	BHITE MAYUR ASHOK	Bhite
36	PAVAN PAWAR	Pavar
37	AKSHAY KUMBHAR	Akshay
38	BOROLE JAYESH RAJENDRA	Borole
39	JADHAV KUNAL BALU	Jadhav
40	MAYUR PAWAR	Mayur
41	BHUIBAL ABHISHEK EKNATH	Bhujbal
42	RODGE RAJKUMAR	Rodge
43	DHOBAL BHUSHAN ABASAHEB	Dhobale
44	DHAVAL ANIKET SHIVAJI	Dhaval
45	CHAKKAR DEEP VINAYAK	Chakkar
46	ABHISHEK THAKUR	Abhishek
47	HARSHAL PAWAR	Harshal
48	KOTKAR JAYESH ARUN	Kotkar

Attendance - Autocad workshop.

16th Oct. 2019

Sr.No	Name of Participant	Sign
1	BHUBAL SHUBHAM SUDAM	S. Sudam
2	BANKAR TEJAS BABASAHEB	T. Babasaheb
3	balkrushan sirsakar	B. Sirsakar
4	PAWANKUMAR PAWAR	P. Pawar
5	SNEHAL SAKALKAR	S. Sakalkar
6	NADAR SHISUNDAR	N. Shisundar
7	GAJARE ASHISH SANJAY	G. Ashish
8	BALI AKASH RAJKUMAR	B. Akash
9	SHANTANU AMBEKAR	S. Ambekar
10	BIRADAR ABHISHEK SURYAKANT	B. Abhishek
11	BORAWANE SUHAS BALASO	B. Suhas
12	AKSHAY KOTKAR	A. Kotkar
13	CHENDKE MADHUSUDHAN TANAJI	C. Madhusudhan
14	AKSHAY KUMBHAR	A. Kumbhar
15	DIGVIJAY PAWAR	D. Digvijay
16	MEDIBOYNA RAVIKUMAR	M. Ravikumar
17	SANDIP HIPPARGEKAR	S. Hippargekar
18	ANUJ AMRUTKAR	A. Amrutkar
19	CHIKANE VIJAY BALKRUSHNA	C. Vijay
20	GHUGE SATISHKUMAR BALASAHEB	G. Satishkumar
21	HARSHAL SURESH BARANGE	H. Suresh
22	KAUSTUBH KANGAONKAR	K. Kangaonkar
23	LAXMIKANT KHEDKAR	L. Khedkar
24	AKSHAY KHEDKAR	A. Khedkar
25	DARESH PAWAR	D. Pawar
26	SHUBHAM KUMBHAR	S. Kumbhar
27	DARANDALE RUSHIKESH SACHIN	D. Rushikesh
28	KHOCHARE DEEAPK KANTILAL	K. Deeapk
29	NAGRAJ KALYANKAR	N. Kalyankar
30	SHITAL BHASAR	S. Bhasar
31	BAHIRE ISHWAR	B. Ishwar
32	ASHRUBA DEVKAR	A. Devkar
33	ANAND GAYKAR	A. Gaykar
34	DHIRAJ KINHOLKAR	D. Kinholkar
35	BHITE MAYUR ASHOK	B. Mayur
36	PAVAN PAWAR	P. Pawar
37	AKSHAY KUMBHAR	A. Kumbhar
38	BOROLE JAYESH RAJENDRA	B. Jayesh
39	JADHAV KUNAL BALU	J. Kunal
40	MAYUR PAWAR	M. Pawar
41	BHUBAL ABHISHEK EKNATH	B. Abhishek
42	RODGE RAJKUMAR	R. Rajkumar
43	DHOBAL BHUSHAN ABASAHEB	D. Bhushan
44	DHAVAL ANIKET SHIVAJI	D. Aniket
45	CHAKKAR DEEP VINAYAK	C. Deep
46	ABHISHEK THAKUR	A. Thakur
47	HARSHAL PAWAR	H. Pawar
48	KOTKAR JAYESH ARUN	K. Jayesh

Attendance - Autocad workshop.

18th Oct. 2019

Sr.No	Name of Participant	Sign
1	BHUJBAL SHUBHAM SUDAM	Shubham
2	BANKAR TEJAS BARASAHER	Tejas
3	balkrushan sirakar	Balkrushan
4	PAWANKUMAR PAWAR	Pawankumar
5	SNEHAL SAKALKAR	Snehal
6	NADAR SHISUNDAR	Nadar
7	GAJARE ASHISH SANJAY	Gajare
8	BALI AKASH RAJKUMAR	Bali
9	SHANTANU AMBEKAR	Shantanu
10	BIRADAR ABHISHEK SURYAKANT	Biradar
11	BORAWANE SUHAS BALASO	Borawane
12	AKSHAY KOTKAR	Akshay
13	CHENDKE MADHUSUDHAN TANAJI	Chendke
14	AKSHAY KUMBHAR	Akshay
15	DIGVIJAY PAWAR	Digvijay
16	MEDIBOYNA RAVIKUMAR	Mediboyna
17	SANDIP HIPPARGEKAR	Sandip
18	ANUJ AMRUTKAR	Anuj
19	CHIKANE VIJAY BALKRUSHNA	Chikane
20	GHUGE SATISHKUMAR BALASAHEB	Ghughe
21	HARSHAL SURESH BARANGE	Harshal
22	KAUSTUBH KANGAONKAR	Kaustubh
23	LAXMIKANT KHEDKAR	Laxmikant
24	AKSHAY KHEDKAR	Akshay
25	DARESH PAWAR	Dareesh
26	SHUBHAM KUMBHAR	Shubham
27	DARANDALE RUSHIKESH SACHIN	Darandale
28	KHOCHARE DEEAPK KANTILAL	Khochare
29	NAGRAJ KALYANKAR	Nagraj
30	SHITAL BHASAR	Shital
31	BAHIRE ISHWAR	Bahire
32	ASHRUBA DEVKAR	Ashruba
33	ANAND GAYKAR	Anand
34	DHIRAJ KINHOLKAR	Dhiraj
35	BHITE MAYUR ASHOK	Bhite
36	PAVAN PAWAR	Pavan
37	AKSHAY KUMBHAR	Akshay
38	BOROLE JAYESH RAJENDRA	Borole
39	JADHAV KUNAL BALU	Jadhav
40	MAYUR PAWAR	Mayur
41	BHUJBAL ABHISHEK EKNATH	Bhujbal
42	RODGE RAJKUMAR	Rodge
43	DHOBABLE BHUSHAN ABASAHEB	Dhobable
44	DHAVAL ANIKET SHIVAJI	Dhaval
45	CHAKKAR DEEP VINAYAK	Chakkar
46	ABHISHEK THAKUR	Abhishek
47	HARSHAL PAWAR	Harshal
48	KOTKAR JAYESH ARUN	Kotkar

Jaywant Shikshan Prasarak Mandal's

**Imperial College of Engineering and Research,
Wagholi, Pune, India.**



(Accredited by NAAC 'A' Grade, affiliated to Savitribai Phule Pune University)

Mechanical Engineering Department

CERTIFICATE OF PARTICIPATION

This is to certify that **Mr. GAJARE ASHISH**, has participated and completed in One Week Hands-on training on **"AutoCAD"** held on 15th -19th Oct. 2019 Best wishes!

Prof.N.A.Kadlak
Co-ordinator, Mech Dept.
ICOER, Wagholi

Dr.Sarje S.H.
HoD, JSPM's ICOER,
Wagholi

Dr. D.D.Shah
Principal, JSPM's ICOER,
Wagholi

Jaywant Shikshan Prasarak Mandal's

**Imperial College of Engineering and Research,
Wagholi, Pune, India.**



(Accredited by NAAC 'A' Grade, affiliated to Savitribai Phule Pune University)

Mechanical Engineering Department

CERTIFICATE OF PARTICIPATION

This is to certify that **Mr. SHANTANU AMBEKAR**, has participated and completed in One Week Hands-on training on **"AutoCAD"** held on 15th -19th Oct. 2019 Best wishes!

Prof.N.A.Kadlak
Co-ordinator, Mech Dept.
ICOER, Wagholi

Dr.Sarje S.H.
HoD, JSPM's ICOER,
Wagholi

Dr. D.D.Shah
Principal, JSPM's ICOER,
Wagholi

Jaywant Shikshan Prasarak Mandal's

**Imperial College of Engineering and Research,
Wagholi, Pune, India.**



(Accredited by NAAC 'A' Grade, affiliated to Savitribai Phule Pune University)

Mechanical Engineering Department

CERTIFICATE OF PARTICIPATION

This is to certify that **Mr. DIGVIJAY PAWAR**, has participated and completed in One Week Hands-on training on **"AutoCAD"** held on 15th -19th Oct. 2019 Best wishes!

Prof.N.A.Kadlak
Co-ordinator, Mech Dept.
ICOER, Wagholi

Dr.Sarje S.H.
HoD, JSPM's ICOER,
Wagholi

Dr. D.D.Shah
Principal, JSPM's ICOER,
Wagholi

Jaywant Shikshan Prasarak Mandal's

**Imperial College of Engineering and Research,
Wagholi, Pune, India.**



(Accredited by NAAC 'A' Grade, affiliated to Savitribai Phule Pune University)

Mechanical Engineering Department

CERTIFICATE OF PARTICIPATION

This is to certify that **Mr. SHUBHAM KUMBHAR**, has participated and completed in One Week Hands-on training on **"AutoCAD"** held on 15th -19th Oct. 2019 Best wishes!

Prof.N.A.Kadlak
Co-ordinator, Mech Dept.
ICOER, Wagholi

Dr.Sarje S.H.
HoD, JSPM's ICOER,
Wagholi

Dr. D.D.Shah
Principal, JSPM's ICOER,
Wagholi



Jaywant Shikshan Prasarak Mandal's

**Imperial College of Engineering and
Research, Wagholi, Pune, India.**

(Accredited by NAAC 'A' Grade, affiliated to Savitribai Phule Pune University)

Mechanical Engineering Department



CERTIFICATE OF PARTICIPATION

This is to certify that **Mr. SNEHAL SAKALKAR**, has participated and completed in One Week Hands-on training on **“AutoCAD”** held on 15th -19th Oct. 2019 Best wishes!

Prof.N.A.Kadlak
Co-ordinator, Mech Dept.
ICOER, Wagholi

Dr.Sarje S.H.
HoD, JSPM's ICOER,
Wagholi

Dr. D.D.Shah
Principal, JSPM's ICOER,
Wagholi